

Kg. ED-350 = 42 kg

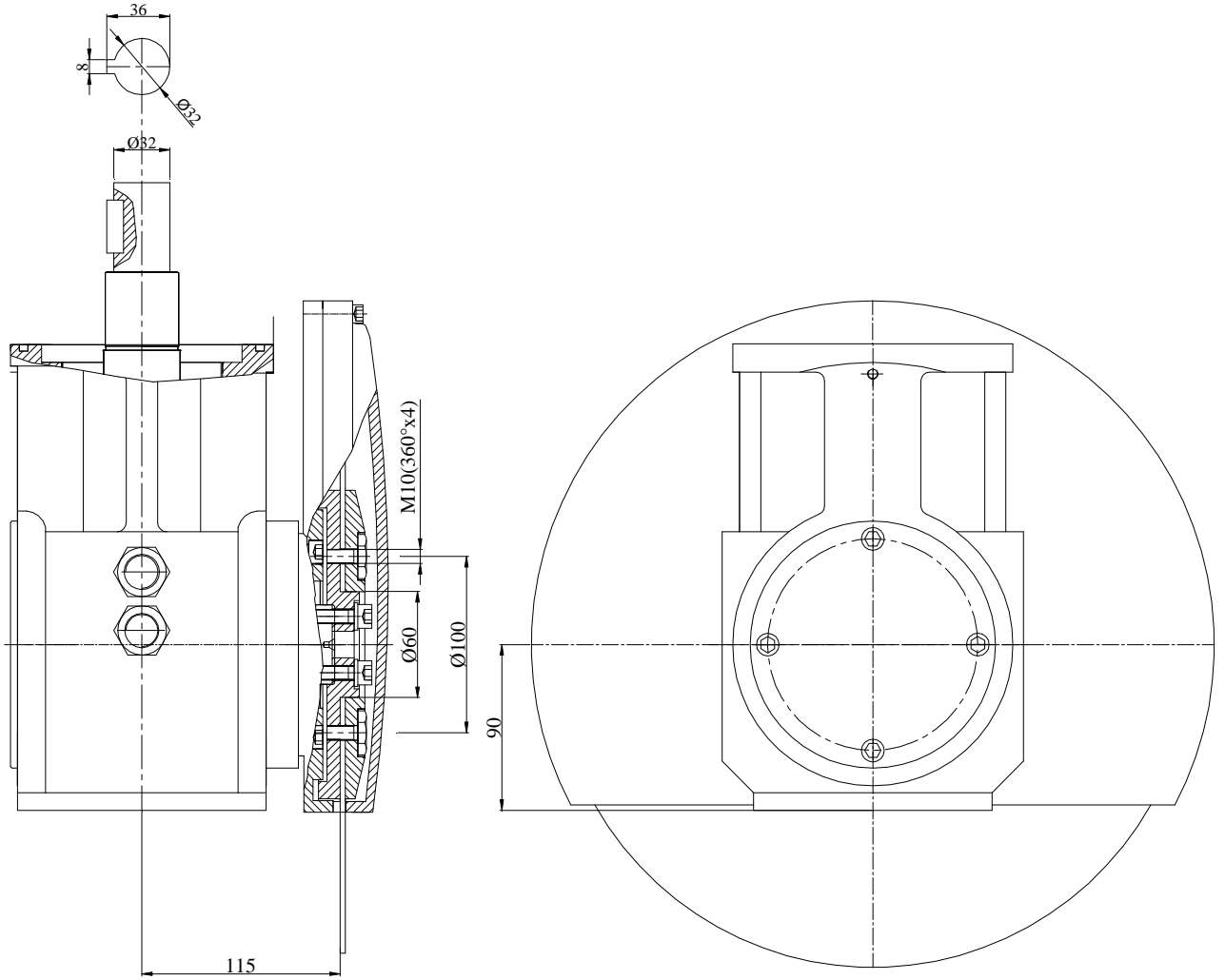

**YAĞ MİKTARI
OIL AMOUNT 0,75 lt**

TEKNİK ÖZELLİKLER

TECHNICAL FEATURES

●	Testere Çapı	Saw Diameter	350 mm						
●	Min. Kesme Geniřlięi	Min. Cutting Width	198 mm						
●	Kullanılan Motor Aralıęı	Motor Range Used	4 - 5,5 kw						
●	Max. Kesme Kalınlıęı	Max. Cutting Thickness	30 mm						
Yaę Cinsi Oil type	Kullanım Sıcaklıęı Usage Temperature (°C)	ISO Viskozite Sınıfı ISO Viscosity Class	Kullanılan Yaęlar / Oils used						
			ARAL	BP	ESSO	KLUBER	MOBIL	SHELL	TEXAGO
Mineral Yaęlar Mineral Oils	-5.....+100	ISO VG 220	Degol BG 220	Energol GR-XP 220	Spartan EP 220	Gem1 220	MobilGear 630	Omala 220	Meropa 220
Sentetik Yaęlar Synthetic Oils	-25.....+140	ISO VG 220	Degol GS 220	Enersyn SG-XP 220		Syntheso D 220 EP	Gylgoyle HE 220	Tivela WB	Synlube CLP 220