

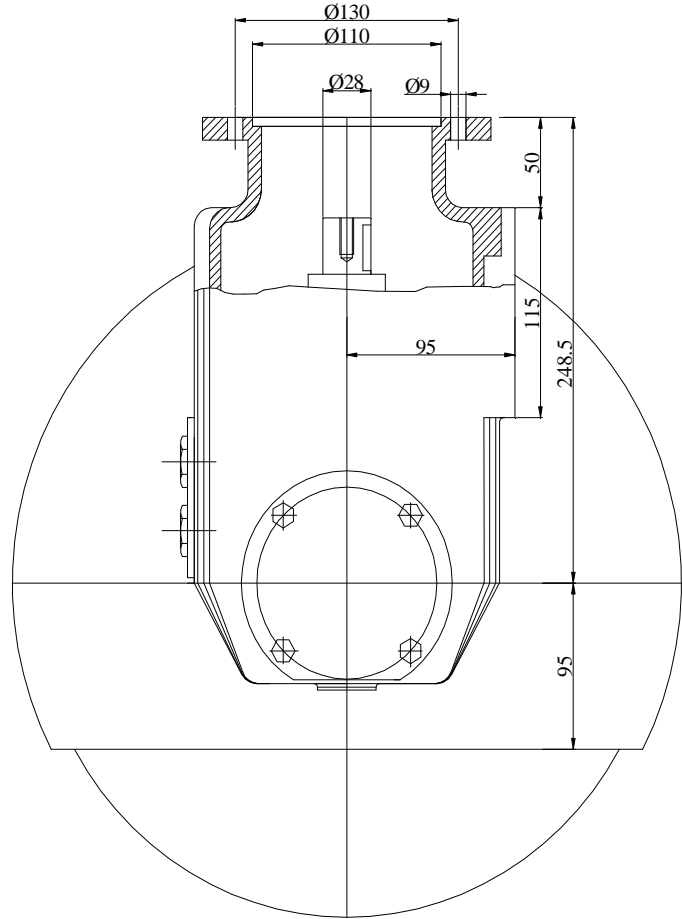

Kg. E-350 = 38 kg

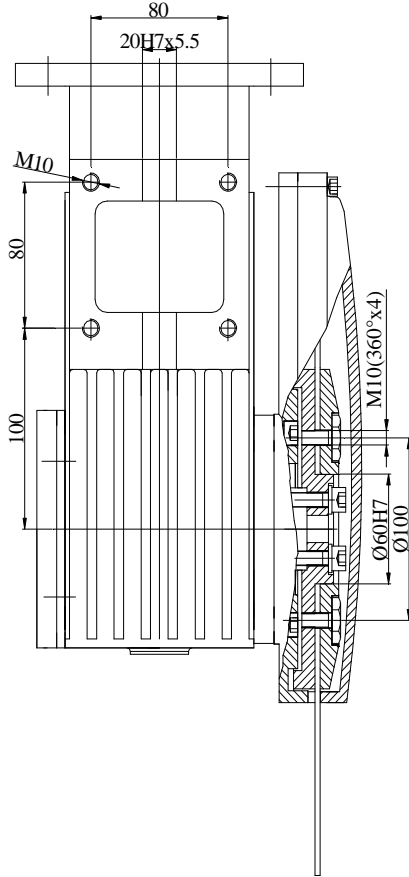

**YAĞ MİKTARI
OIL AMOUNT 0,75 lt**

TEKNİK ÖZELLİKLER

TECHNICAL FEATURES



Testere Çapı
Min. Kesme Genişliği
Kullanılan Motor Aralığı
Max. Kesme Kalınlığı

Saw Diameter
Min. Cutting Width
Motor Range Used
Max. Cutting Thickness

350 mm
190 mm
4 - 5,5 kw
30 mm

Yağ Cinsi Oil type	Kullanım Sıcaklığı Usage Temperature (°C)	ISO Viskozite Sınıfı ISO Viscosity Class	Kullanılan Yağlar / Oils used						
			ARAL	BP	ESSO	KLUBER	MOBIL	SHELL	TEXAGO
Mineral Yağlar Mineral Oils	-5.....+100	ISO VG 220	Degol BG 220	Energol GR-XP 220	Spartan EP 220	Gem1 220	MobilGear 630	Omala 220	Meropa 220
Sentetik Yağlar Synthetic Oils	-25.....+140	ISO VG 220	Degol GS 220	Energol SG-XP 220		Syntheso D 220 EP	Gylgoyle HE 220	Tivela WB	Synlube CLP 220